

## FLANGE ADAPTOR (SHORT) / FLANŞ ADAPTÖR (KISA)

SDR11 PE100

GAS/GAZ : 10 BAR

WATER/SU : 16 BAR

TYPE/TİP : SPIGOT

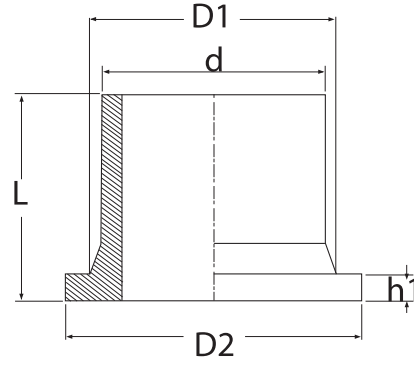

d	CODE	Kg.	L (mm)	D1 (mm)	D2 (mm)	h1 (mm)	box sizes	nos/box
140	30.FAK.00.11.0140	1,20	134	150	188	26	60x40x45	12
160	30.FAK.00.11.0160	1,45	134	170	210	25	60x40x45	12
200	30.FAK.00.11.0200	2,75	142	225	268	32	60x40x45	6
355	30.FAK.00.11.0355	6,17	180	370	430	40	60x40x45	1
400	30.FAK.00.11.0400	11,50	191	425	482	46	60x40x45	1
450	30.FAK.00.11.0450	20,10	220	510	560	60	60x60x33	1
450-B	30.FAK.00.11.0450	20,1	220	458	550	60	60x60x33	1
500	30.FAK.00.11.0500	22,60	210	525	585	60	*	*
560	30.FAK.00.11.0560	31,10	240	610	685	60	*	*
630	30.FAK.00.11.0630	32,40	220	640	685	60	*	*
710	30.FAK.00.11.0710	39,30	230	730	800	60	*	*
800	30.FAK.00.11.0800	53,20	230	840	905	60	*	*
900	30.FAK.00.11.0900	71,00	240	944	1000	60	*	*

(\*) No box is used. Only Euro pallets are being used.