

ELBOW (45°) / DİRSEK (45°)
 SDR11 PE100
 GAS/GAZ : 10 BAR
 WATER/SU : 16 BAR
 TYPE/TİP : SPIGOT

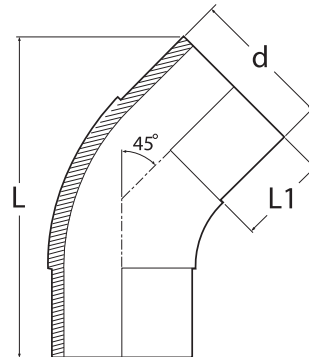

d	CODE	Kg.	L(mm)	L1 (mm)	box sizes	nos/box
20	30.DK0.00.11.0020	0,02	36	80	40*30*15	200
25	30.DK0.00.11.0025	0,03	43	100	40*30*15	100
32	30.DK0.00.11.0032	0,04	50	115	40*30*15	65
40	30.DK0.00.11.0040	0,07	53	130	40*30*30	80
50	30.DK0.00.11.0050	0,11	57	140	40*30*30	50
63	30.DK0.00.11.0063	0,19	65	160	40*30*30	30
75	30.DK0.00.11.0075	0,44	88	210	60*40*30	30
90	30.DK0.00.11.0090	0,49	90	215	60*40*30	25
110	30.DK0.00.11.0110	0,88	92	250	60*40*30	15
125	30.DK0.00.11.0125	1,30	100	285	60*40*30	10
140	30.DK0.00.11.0140	2,60	115	315	60*40*30	10
160	30.DK0.00.11.0160	2,47	115	320	60*40*45	6
180	30.DK0.00.11.0180	2,85	120	360	60*40*45	6
200	30.DK0.00.11.0200	4,24	120	360	60*40*45	4
225	30.DK0.00.11.0225	5,46	140	450	60*40*45	2
250	30.DK0.00.11.0250	6,7	140	450	60*40*30	1
280	30.DK0.00.11.0280	17,40	140	450	60*40*30	1
315	30.DK0.00.11.0315	13,20	150	500	60*40*45	1