

ELBOW (45°) SEGMENTED / DİRSEK (45°) KONFEKSİYON

SDR17 PE100

GAS/GAZ : 6 BAR

WATER/SU : 10 BAR

TYPE/TİP : SPIGOT

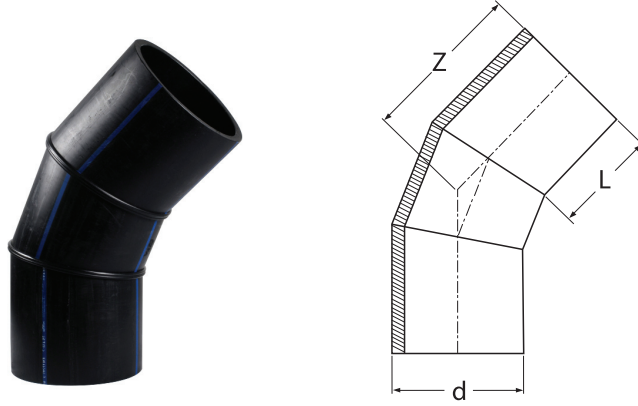

D	CODE	Kg.	L(mm)	Z (mm)
160	35.DK0.00.17.0160	2,30	150	250
180	35.DK0.00.17.0180	2,85	150	260
200	35.DK0.00.17.0200	3,60	150	270
225	35.DK0.00.17.0225	4,64	150	290
250	35.DK0.00.17.0250	7,15	250	410
280	35.DK0.00.17.0280	9,18	250	425
315	35.DK0.00.17.0315	12,20	300	495
355	35.DK0.00.17.0355	15,20	300	520
400	35.DK0.00.17.0400	24,15	300	545
450	35.DK0.00.17.0450	36,50	300	580
500	35.DK0.00.17.0500	46,00	350	665
560	35.DK0.00.17.0560	61,00	350	700
630	35.DK0.00.17.0635	76,00	350	740
710	35.DK0.00.17.0710	101,00	350	790
800	35.DK0.00.17.0800	132,00	350	845
900	35.DK0.00.17.0900	157,00	400	945
1000	35.DK0.00.17.1000	202,00	400	990