

REDUCED TEE (SHORT) / INEGAL TE (KISA)

SDR11 PE100

GAS/GAZ : 10 BAR

WATER/SU : 16 BAR

TYPE/TİP : SPIGOT

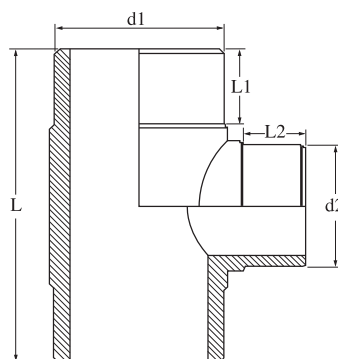

d1*d2	CODE	Kg.	L(mm)	L1(mm)	L2 (mm)	box sizes	nos/box
160*75	30.ITK.00.11.1675	2,10	275	60	75	60*40*45	4 **
160*90	30.ITK.00.11.1690	2,20	275	60	95	60*40*45	3 *
160*140	30.ITK.00.11.1614	3,40	335	60	110	60*40*45	2 *
180*75	30.ITK.00.11.1875	2,60	275	60	75	60*40*45	2 **
180*110	30.ITK.00.11.1811	3,40	320	60	105	60*40*45	2 *
180*125	30.ITK.00.11.1812	3,60	320	60	110	60*40*45	2 *
180*140	30.ITK.00.11.1814	4,00	335	60	110	60*40*45	2 **
180*160	30.ITK.00.11.1816	4,90	375	60	120	60*40*45	2 **
200*75	30.ITK.00.11.2075	3,20	275	60	75	60*40*45	2 **
200*90	30.ITK.00.11.2090	3,25	275	60	90	60*40*45	2 *
200*125	30.ITK.00.11.2012	4,20	320	60	110	60*40*45	2 **
200*140	30.ITK.00.11.2014	4,70	335	60	110	60*40*45	2 *
200*160	30.ITK.00.11.2016	5,60	375	60	120	60*40*45	2 **
200*180	30.ITK.00.11.2018	6,20	375	60	125	60*40*45	2 *
225*75	30.ITK.00.11.2275	5,20	375	60	75	60*40*45	2 **
225*90	30.ITK.00.11.2290	4,00	275	60	90	60*40*45	2 *
225*110	30.ITK.00.11.2211	4,90	320	60	105	60*40*45	2 *
225*125	30.ITK.00.11.2212	5,00	320	60	110	60*40*45	2 **
225*140	30.ITK.00.11.2214	5,60	335	60	110	60*40*45	2 **
225*160	30.ITK.00.11.2216	6,60	375	60	120	60*40*45	2 *
225*180	30.ITK.00.11.2218	7,30	375	60	125	60*40*45	2 **
225*200	30.ITK.00.11.2220	8,60	425	60	130	60*40*30	2 **
250*75	30.ITK.00.11.2575	4,70	275	60	75	60*40*45	2 **
250*90	30.ITK.00.11.2590	4,80	275	60	90	60*40*45	2 *
250*110	30.ITK.00.11.2511	5,90	320	60	105	60*40*30	1 *
250*125	30.ITK.00.11.2512	6,00	320	60	110	60*40*30	1 *

REDUCED TEE (SHORT) / INEGAL TE (KISA)

SDR11 PE100
GAS/GAZ : 10 BAR
WATER/SU : 16 BAR
TYPE/TIP : SPIGOT



d1*d2	CODE	Kg.	L(mm)	L1(mm)	L2 (mm)	box sizes	nos/box	
250*140	30.ITK.00.11.2514	6,60	335	60	110	60*40*30	1	**
250*160	30.ITK.00.11.2516	7,80	375	60	120	60*40*30	1	*
250*180	30.ITK.00.11.2518	8,40	375	60	125	60*40*45	1	*
250*200	30.ITK.00.11.2520	9,80	425	60	130	60*40*45	1	*
250*225	30.ITK.00.11.2522	10,30	425	60	130	60*40*45	1	**
280*75	30.ITK.00.11.2875	5,80	275	60	75	60*40*30	1	**
280*90	30.ITK.00.11.2890	5,90	275	60	90	60*40*30	1	**
280*110	30.ITK.00.11.2811	7,10	320	60	105	60*40*30	1	**
280*125	30.ITK.00.11.2812	7,30	320	60	110	60*40*30	1	**
280*140	30.ITK.00.11.2814	7,90	335	60	110	60*40*30	1	**
280*160	30.ITK.00.11.2816	9,30	375	60	120	60*40*30	1	**
280*180	30.ITK.00.11.2818	9,90	375	60	125	***		**
280*200	30.ITK.00.11.2820	11,50	425	60	130	***		**
280*225	30.ITK.00.11.2822	12,00	425	60	130	***		**
280*250	30.ITK.00.11.2825	15,10	465	60	145	***		**
315*90	30.ITK.00.11.3190	7,40	275	60	90	***		**
315*110	30.ITK.00.11.3111	8,90	320	60	105	***		**
315*125	30.ITK.00.11.3112	9,00	320	60	110	***		**
315*140	30.ITK.00.11.3114	9,70	335	60	110	***		**
315*160	30.ITK.00.11.3116	11,30	375	60	120	***		**
315*180	30.ITK.00.11.3118	11,90	375	60	125	***		**
315*200	30.ITK.00.11.3120	13,80	425	60	130	***		**
315*225	30.ITK.00.11.3122	14,30	425	60	130	***		**
315*250	30.ITK.00.11.3125	17,60	465	60	145	***		**
315*280	30.ITK.00.11.3128	20,30	560	60	150	***		**
355*90	30.ITK.00.11.3590	11,10	335	90	90	***		**
355*110	30.ITK.00.11.3511	13,00	380	90	105	***		**
355*125	30.ITK.00.11.3512	13,10	380	90	110	***		**
355*140	30.ITK.00.11.3514	13,90	395	90	110	***		**
355*160	30.ITK.00.11.3516	15,80	435	90	120	***		**
355*180	30.ITK.00.11.3518	16,40	435	90	125	***		**
355*200	30.ITK.00.11.3520	18,60	485	90	130	***		**
355*225	30.ITK.00.11.3522	19,10	485	90	130	***		**
355*250	30.ITK.00.11.3525	22,70	525	90	145	***		**
355*280	30.ITK.00.11.3528	16,10	620	90	150	***		**
400*90	30.ITK.00.11.4090	14,10	335	90	90	***		**
400*110	30.ITK.00.11.4011	16,30	380	90	105	***		**
400*125	30.ITK.00.11.4012	16,40	380	90	110	***		**
400*140	30.ITK.00.11.4014	17,40	395	90	110	***		**
400*160	30.ITK.00.11.4016	19,50	435	90	120	***		**
400*180	30.ITK.00.11.4018	20,10	435	90	125	***		**
400*200	30.ITK.00.11.4020	22,80	485	90	130	***		**
400*225	30.ITK.00.11.4022	23,30	485	90	130	***		**
400*250	30.ITK.00.11.4025	27,20	525	90	145	***		**
400*280	30.ITK.00.11.4028	31,40	620	90	150	***		**
400*315	30.ITK.00.11.4031	34,40	670	90	155	***		**
450*90	30.ITK.00.11.4035	17,80	335	90	90	***		**
450*110	30.ITK.00.11.4511	20,40	380	90	105	***		**
450*125	30.ITK.00.11.4512	20,50	380	90	110	***		**
450*140	30.ITK.00.11.4514	21,70	395	90	110	***		**
450*160	30.ITK.00.11.4516	24,30	435	90	120	***		**
450*180	30.ITK.00.11.4518	24,90	435	90	125	***		**

EF METRIK

EF INCH

SPIGOT

VANA VALVE

MAKINE VE APARAT MACHINES & TOOL

MONTAJ INSTALLATION

TEKNIK TECHNICAL

REDUCED TEE (SHORT) / INEGAL TE (KISA)

SDR11 PE100
GAS/GAZ : 10 BAR
WATER/SU : 16 BAR
TYPE/TİP : SPIGOT

d1*d2	CODE	Kg.	L(mm)	L1(mm)	L2 (mm)	box sizes	nos/box
450*200	30.ITK.00.11.4520	28,10	485	90	130	***	**
450*225	30.ITK.00.11.4522	28,60	485	90	130	***	**
450*250	30.ITK.00.11.4525	32,90	525	90	145	***	**
450*280	30.ITK.00.11.4528	38,20	620	90	150	***	**
450*315	30.ITK.00.11.4531	41,70	670	90	155	***	**
500*90	30.ITK.00.11.5090	21,80	335	90	90	***	**
500*110	30.ITK.00.11.5011	25,00	380	90	105	***	**
500*125	30.ITK.00.11.5012	25,10	380	90	110	***	**
500*140	30.ITK.00.11.5014	26,40	395	90	110	***	**
500*160	30.ITK.00.11.5016	29,50	435	90	120	***	**
500*180	30.ITK.00.11.5018	30,10	435	90	125	***	**
500*200	30.ITK.00.11.5020	34,00	485	90	130	***	**
500*225	30.ITK.00.11.5022	34,50	485	90	130	***	**
500*250	30.ITK.00.11.5025	39,30	525	90	145	***	**
500*280	30.ITK.00.11.5028	45,70	620	90	150	***	**
560*90	30.ITK.00.11.5690	28,80	335	90	90	***	**
560*110	30.ITK.00.11.5611	32,70	380	90	105	***	**
560*125	30.ITK.00.11.5612	32,90	380	90	110	***	**
560*140	30.ITK.00.11.5614	34,40	395	90	110	***	**
560*160	30.ITK.00.11.5616	38,20	435	90	120	***	**
560*180	30.ITK.00.11.5618	38,80	435	90	125	***	**
560*200	30.ITK.00.11.5620	43,40	485	90	130	***	**
560*225	30.ITK.00.11.5622	43,90	485	90	130	***	**
560*250	30.ITK.00.11.5625	49,30	525	90	145	***	**
560*280	30.ITK.00.11.5628	57,30	620	90	150	***	**
630*90	30.ITK.00.11.6390	36,40	335	90	90	***	**
630*110	30.ITK.00.11.6311	41,20	400	100	105	***	**
630*125	30.ITK.00.11.6312	41,40	400	100	110	***	**
630*140	30.ITK.00.11.6314	43,30	415	100	110	***	**
630*160	30.ITK.00.11.6316	47,90	455	100	120	***	**
630*180	30.ITK.00.11.6318	48,50	455	100	125	***	**
630*200	30.ITK.00.11.6320	54,20	505	100	130	***	**
630*225	30.ITK.00.11.6322	54,70	505	100	130	***	**
630*250	30.ITK.00.11.6325	61,00	545	100	145	***	**
630*280	30.ITK.00.11.6328	70,90	640	100	150	***	**
630*315	30.ITK.00.11.6331	77,00	690	100	155	***	**

Bigger sizes are available upon request.

“(*) : Injected

“(**) : Produced by EF saddle”

“(***) No box is used. Only Euro pallets are being used.