

SDR11 ELECTROFUSION 90 DEGREE ELBOWS

Water - 240 PSI at 73 Deg F Sustainable Maximum Operating Pressure

Gas - 150 PSI at 73 Deg F Sustainable Maximum Operating Pressure

- Suitable for Water, Fluids & Slurry's
- Engineered for PE3408, PE4710 & PE100 HDPE Pipe Systems
- Manufactured in accordance with ASTM F-714, ASTM F-1055, ASTM D-2513, ASTM D-3035, ASTM D-3261, ASTM D-3350, AWWA C-901, AWWA C-906, DIN16963, EN1555, EN12201 ISO-9001 Certified

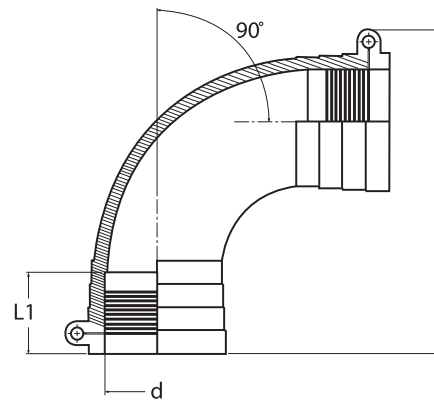

Nominal Pipe Size d	Base Norm	L	L1	Unit Weight in lbs.	Item Code
3/4"	IPS	3,86	1,50	0,15	30.DD1.11.11.0026
1"	CTS	4,29	1,61	0,31	30.DD1.33.11.0028
1"	IPS	4,29	1,61	0,22	30.DD1.11.11.0033
1 1/4"	IPS	5,16	1,85	0,37	30.DD1.11.11.0042
1 1/2"	IPS	6,10	2,01	0,62	30.DD1.11.11.0048
2"	IPS	7,44	1,89	1,15	30.DD1.11.11.0060
3"	IPS	9,53	2,76	2,45	30.DD1.11.11.0088
4"	IPS	11,69	3,23	6,61	30.DD1.11.11.0114