

## SDR11-ELECTROFUSION COUPLER DIPS

**Water** 200-240 PSI at 73 Deg F Sustainable  
Maximum Operating Pressure

- Suitable for Water, Fluids & Slurry's
- Engineered for PE3408, PE4710 & PE100 HDPE Pipe Systems
- Manufactured in accordance with ASTM F-714, ASTM F-1055, ASTM D-2513, ASTM D-3035, ASTM D-3261, ASTM D-3350, AWWA C-901, AWWA C-906, DIN16963, EN1555, EN12201 ISO-9001 Certified

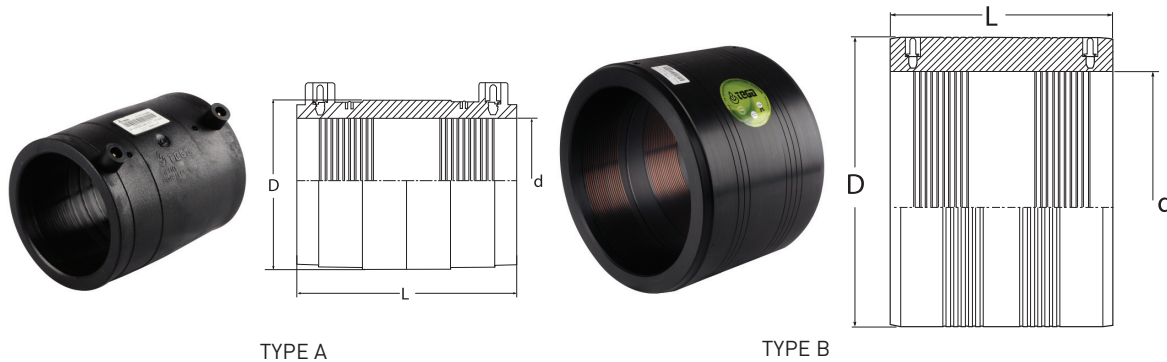

TYPE A

TYPE B

Nominal DIPS Pipe Size	ID (Nominal) d	D	L	Unit Weight in lbs.	TYPE	Item Code
4"	4,80	6,30	6,60	3,00	A	30.MA1.22.11.0121
6"	6,90	8,40	7,50	4,70	B	30.MA1.22.11.0175
8"	9,05	10,60	8,00	6,70	B	30.MA1.22.11.0229***
10"	11,10	13,00	8,60	13,80	B	30.MA1.22.11.0281**
12"	13,20	15,35	9,50	24,00	B	30.MA1.22.11.0335
14" (1)	15,30	18,30	11,80	41,50	B	30.MA1.22.11.0388
16" (1)	17,40	20,86	12,60	56,30	B	30.MA1.22.11.0441
18" (1)	19,50	23,20	14,40	68,50	B	30.MA1.22.11.0495**
20" (1)	21,60	26,50	15,70	115,00	B	30.MA1.22.11.0548
24" (1)	25,80	31,50	16,50	156,50	B	30.MA1.22.11.0655
30" (1)	32,00	38,50	18,50	246,60	B	30.MA1.22.11.0812***

(1) Separate fusion zones

\*\* 220 psi

\*\*\* 200 psi