

SDR17 ELECTROFUSION COUPLER DIPS

Water 160 PSI at 73 Deg F Sustainable Maximum Operating Pressure

- Suitable for Water, Fluids & Slurry's
- Engineered for PE3408, PE4710 & PE100 HDPE Pipe Systems
 - Manufactured in accordance with ASTM F-714, ASTM F-1055, ASTM D2513, ASTM D-3035, ASTM D-3261, ASTM D-3350, AWWA C-901, AWWA, C-906, DIN 16963, EN1555, EN12201 ISO-9001 Certified

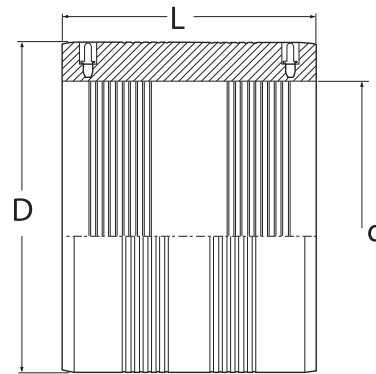

Nominal DIPS Pipe Size	ID (Nominal) d	D	L	Unit Weight in lbs.	Item Code
6"	6,90	8,10	7,50	3,50	30.MA1.22.17.0175
8"	9,05	10,60	7,80	5,70	30.MA1.22.17.0229
10"	11,10	13,00	8,60	10,60	30.MA1.22.17.0281
12"	13,20	15,35	9,50	16,00	30.MA1.22.17.0335
14" (1)	15,30	18,30	11,80	29,80	30.MA1.22.17.0388
16" (1)	17,40	20,86	12,60	45,10	30.MA1.22.17.0441
18" (1)	19,50	23,20	14,40	54,60	30.MA1.22.17.0495
20" (1)	21,60	26,50	15,70	88,50	30.MA1.22.17.0548
24" (1)	25,80	30,50	16,50	112,70	30.MA1.22.17.0655
30" (1)	32,00	37,40	18,50	179,50	30.MA1.22.17.0812

(1) Separate fusion zones