

### SDR7,4 ELECTROFUSION COUPLER IPS

**Water** 360 PSI at 73 Deg F Sustainable Maximum Operating Pressure

- Suitable for Water, Fluids & Slurry's
- Engineered for PE3408, PE4710 & PE100 HDPE Pipe Systems
- Manufactured in accordance with ASTM F-714, ASTM F-1055, ASTM D-2513, ASTM D-3035, ASTM D-3261, ASTM D-3350, AWWA C-901, AWWA C-906, DIN16963, EN1555, EN12201 ISO-9001 Certified

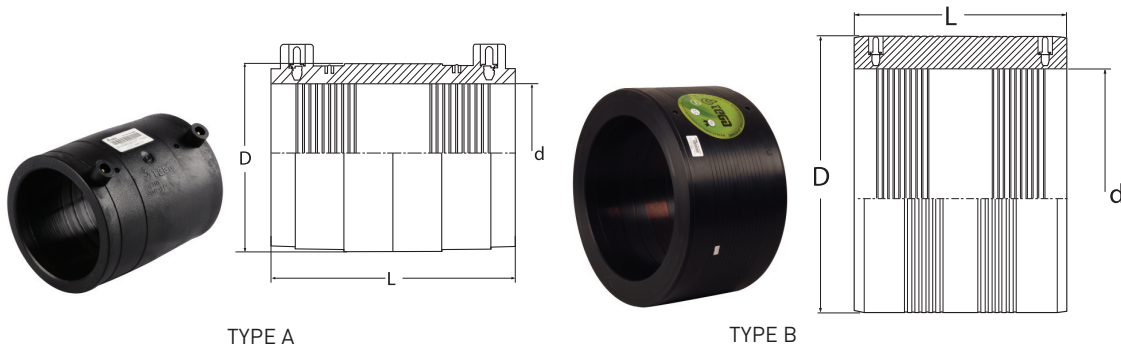

Nominal IPS Pipe Size	ID (Nominal) d	D	L	Unit Weight in lbs.	TYPE	Item Code
2"	2,375	3,82	4,65	1,13	A	30.MA1.11.07.0060
3"	3,500	5,59	6,57	3,40	A	30.MA1.11.07.0088
4"	4,500	6,26	6,77	3,49	A	30.MA1.11.07.0114
5"	5,563	8,03	7,28	6,65	A	30.MA1.11.07.0141
6"	6,625	9,45	7,48	9,24	B	30.MA1.11.07.0168
7"	7,125	9,76	7,48	9,08	B	30.MA1.11.07.0180 *
8"	8,625	12,20	7,87	15,98	B	30.MA1.11.07.0219
10"	10,750	15,35	8,66	28,34	B	30.MA1.11.07.0273
12"	12,750	17,32	9,06	33,90	B	30.MA1.11.07.0323 *
14"	14,000	19,29	10,04	48,15	B	30.MA1.11.07.0355 *
16" (1)	16,000	21,77	11,81	70,10	B	30.MA1.11.07.0406 *
18" (1)	18,000	24,41	12,60	93,23	B	30.MA1.11.07.0457 *
20" (1)	20,000	27,17	14,37	132,22	B	30.MA1.11.07.0508 *
22" (1)	22,000	30,71	15,75	196,80	B	30.MA1.11.07.0558

(1) Separate fusion zones

\* 350 PSI