

**EF ELBOW 90° / EF DİRSEK 90°**  
 SDR 11 PE100  
 GAS / GAZ : 10 BAR  
 WATER / SU : 16 BAR

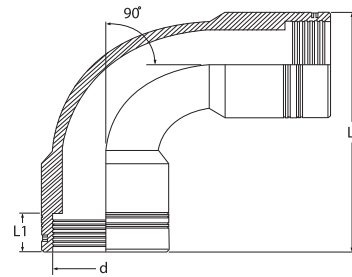

TYPE A

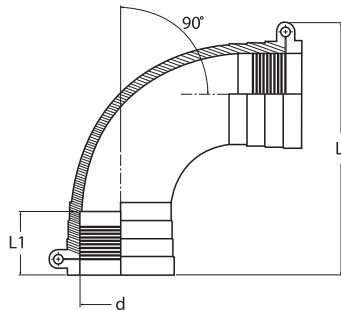

TYPE B



TYPE C

d	CODE	Kg.	L(mm)	L1 (mm)	box sizes	nos/box	Type
20	30.DD1.00.11.0020	0,08	98	38	30*40*15	60	A
25	30.DD1.00.11.0025	0,07	98	38	30*40*15	50	A
32	30.DD1.55.11.0032	0,10	109	41	30*40*30	60	A
40	30.DD1.55.11.0040	0,18	131	47	30*40*30	35	A
50	30.DD1.55.11.0050	0,27	155	51	30*40*30	20	A
63	30.DD1.55.11.0063	0,50	189	48	60*40*30	25	A
75	30.DD1.55.11.0075	0,74	211	65	60*40*30	15	A
90	30.DD1.55.11.0090	1,11	242	70	60*40*45	15	A
110	30.DD1.55.11.0110	1,95	274	76	60*40*45	10	A
125	30.DD1.55.11.0125	2,86	297	82	60*40*30	4	A
160	30.DD1.00.11.0160	4,62	275	68	60*40*45	4	B
180	30.DD1.00.11.0180	6,50	320	75	60*40*45	2	B
200	30.DD1.00.11.0200	9,30	400	90	60*40*30	1	C
225	30.DD1.00.11.0225	14,00	460	110	60x33x60	1	C
250	30.DD1.00.11.0250	23,00	515	110	*	1	C
315	30.DD1.00.11.0315	35,00	540	115	*	1	C

\* no box is used